



**CBS000A– CBS Kit “A”**

**CBS000B – CBS Kit “B” Dual Pump**

**CBS000C– CBS Kit “C” w/ H.E.P.A**

**CBS000D – CBS Kit “D” Dual Pump w/ H.E.P.A**

**CBS**

**Contained Blast System**

**OPERATIONS AND MAINTENANCE**



© Copyright 2014 by NOVATEK Corporation

All rights reserved printed in the United States of America. No part of this manual may be used or reproduced in any form or by any means, stored in data base or retrieval system, without prior written permission from NOVATEK Corporation.

Making copies of this manual for any purpose other than your own personal use is a violation of the United States copyright laws.

June 1, 2014 issue 1.0

**Specifications subject to changes without notice!**

If you have any questions, please contact us:

NOVATEK CORPORATION

254 Welsh Pool Road

Exton, PA 19341

USA

[www.novatekco.com](http://www.novatekco.com)

Toll Free 866 563-7800

Telephone: +1 610 363-7800

Fax +1 610 363-9620

Email: [Sales@Novatekco.com](mailto:Sales@Novatekco.com)

# OPERATION AND MAINTENANCE MANUAL FOR CONTAINED BLAST SYSTEM KITS

## NOTICE

FOR PROFESSIONAL USE ONLY



## WARNING



**IMPORTANT SAFETY INFORMATION ENCLOSED.  
READ AND UNDERSTAND THIS MANUAL BEFORE OPERATING THIS PRODUCT.**

**IT IS YOUR RESPONSIBILITY TO MAKE THIS SAFETY INFORMATION  
AVAILABLE TO OTHERS THAT WILL OPERATE THIS PRODUCT.**

**FAILURE TO OBSERVE THE FOLLOWING WARNING COULD RESULT IN INJURY.**



### PLACING TOOL IN SERVICE

- Always install, operate, inspect and maintain this product in accordance with all applicable standards and regulations (local, state, country, federal, etc.).
- Compressed air models always use clean, dry air at 90 psi (6.2bar/620kPa) maximum air pressure at the inlet. Higher pressure may result in hazardous situations including excessive speed, rupture, or incorrect output torque or force.
- Electric models must always utilize proper gauge, and rated electrical cords with correct connections.
- Be sure all hoses and fittings are the correctly sized and secured.
- Ensure an accessible emergency shut off has been installed in the air or electrical supply line. Make others aware of its location.
- Do not use damaged, frayed, or deteriorated air hoses and fittings.
- Always use proper gauge electrical cords with correct connections. (When applicable.)
- Electric models must not use damaged, frayed, or deteriorated electrical cords and connections.
- Keep clear of whipping air hoses. Shut off the compressed air before approaching a whipping hose.
- Always turn off and disconnect the tool from its power supply before installing, removing or adjusting any accessory, or before performing any maintenance on the tool.
- Do not lubricate tools with flammable or volatile liquids such as kerosene, diesel or jet fuel. Use only recommended lubricants.
- Keep work area clean, uncluttered, ventilated and illuminated.
- Keep all electrical connections clear of water or other liquids. (When applicable.)
- Do not operate the machine while flammable or volatile liquids such as gasoline, diesel or jet fuel are present. Failure to do so can result in explosion. (When applicable.)
- Do not remove any labels. Replace any damaged label.

### USING THE TOOL

- Always wear protection when operating or performing maintenance on this tool.
- Always wear hearing protection when operating this tool.
- Always use Personal Protective Equipment appropriate to the tool used and material worked. This may include dust mask or other breathing apparatus, safety glasses, ear plugs, gloves, apron, safety shoes, hard hat and other equipment.
- Prevent exposure and breathing of harmful dust and particles created by power tool use:
  - Some dust created by power sanding, sawing, and grinding, drilling, and other construction activities contains chemicals known to cause cancer, birth defects or other reproductive harm. Some examples of these chemicals are:
    - Lead from lead based paints,
    - Crystalline silica from bricks and cement and other masonry products, and
    - Arsenic and chromium from chemically treated lumber
- Your risk from these exposures varies, depending on how often you do this type of work. To reduce your exposure to these chemicals: work in a well ventilated area, and work with approved safety equipment, such as those dust masks that are specially designed to filter out microscopic particles.
- Keep others a safe distance from your work area, or ensure they use appropriate Personal Protective Equipment.
- This tool is not designed for working in explosive environments, including those caused by fumes and dust, or near flammable materials.

- Electrically powered tools are not insulated against electric shock.
- Be aware of buried, hidden or other hazards in your work environment. Do not contact or damage cords, conduits, pipes, or hoses that may contain electrical wires, explosive gases or harmful liquids.
- Keep hands, loose clothing, long hair and jewelry away from working end of tool.
- Power tools can vibrate in use. Vibration, repetitive motions or uncomfortable positions may be harmful to your hands and arms. Stop using any tool if discomfort, tingling feeling or pain occurs. Seek medical advices before resuming use.
- Keep body stance balanced and firm. Do not overreach when operating this tool. Anticipate and be alert for sudden changes in motion, reaction torques, or forces during startup and operation.
- Tool and/or accessories may briefly continue their motion after throttle is released,
- To avoid accidental starting – ensure tool in “off” position before applying air pressure or connecting to electricity. Avoid throttle when carrying, and release throttle with loss of air or electricity.
- Ensure work pieces are secure. Use clamps or vises to hold work piece whenever possible.
- Do not carry or drag the tool by the hose or power cord.
- Do not use power tools when tired, or under the influence of medication, drugs, or alcohol.
- Never us a damaged or malfunctioning tool or accessory,
- Do not modify the tool, safety devices, or accessories.
- Do not use this tool for purposed other than those recommended.
- Use accessories recommended by Novatek Corp.
- Never operate a tool with an accessory unless it is properly installed and the tool is held firmly against the work,
- Always use a retainer, when furnished, in addition to proper barriers to protect persons in surrounding or lower areas from possible ejected accessories.
- When wearing gloves and operating models with inside trigger, always be sure that the gloves will not prevent the trigger from being released.
- Wear safety shoes, hard hat, safety goggles, gloves, dust mask and any other appropriate protective clothing while operating the tool.
- Do no indulge in horseplay. Distraction can cause accidents.
- Keep hands and fingers away from the throttle lever until it is time to operate the tool.
- Never rest the tool on your foot.
- Never point the tool at anyone.
- Compressed air is dangerous. Never point an air hose at yourself or others.
- Never blow clothes free of dust with compressed air.
- Be sure all hose connections are tight. A loose hose not only leaks but can come completely off the tool and while whipping under pressure, can injure the operator and other in the area. Attach safety cables to all hosed to prevent injury in case a hose is accidentally broken.
- Never disconnect a pressurized air hose. Always turn off the air supply and bleed the tool before disconnecting a hose.
- When applicable, the operator must keep limbs and body clear of the chisel. If a chisel breaks, the tool with the broken chisel projecting from the tool will suddenly surge forward.
- Do not ride the tool with one leg over the handle. Injury can result if the chisel breaks while riding the tool.
- Know what is underneath the material being worked. Be alert for hidden water, gas, sewer, telephone or electric lines.
- Use only proper cleaning solvents to clean parts. Use only cleaning solvents which meet current safety and health standards. Use cleaning solvents in a well ventilated area.
- Do not flush the tool or clean any parts with diesel fuel. Diesel fuel residue will ignite in the tool when the tool is operated, causing damage to internal parts. When using models with outside triggers or throttle levers, take care when setting the tool down to prevent accidental operation.
- Do not operate the tool with broken or damaged parts.
- Never start the tool when it is lying on the ground.
- This tool is not designed for working in explosive atmospheres.

---

Refer All Communications to the Nearest  
Novatek Corporation Office or Distributor.

Printed in the U.S.A.



## SECTION I

GENERAL.....	6
--------------	---

## SECTION II

KITS "A" & "B".....	6
KITS "C" & "D".....	6
KITS "A", "B", "C" & "D" - MCV.....	6

## SECTION III

SAFETY.....	6
-------------	---

## SECTION IV

EQUIPMENT IDENTIFICATION & FIELD SET-UP .....	7
KITS "A & B" .....	7
KITS "C & D" .....	7
MULTI-PORT COLLECTIONS VACUUM.....	7

## SECTION V

SET-UP PROCEDURES & EQUIPMENT DESCRIPTION .....	7
---	---

## SECTION VI

START-UP REQUIREMENTS .....	9
OPERATING PROCEDURE .....	9
MAINTENANCE.....	10

## SECTION VII

GENERAL H.E.P.A. FILTER CARE .....	10
TROUBLESHOOTING .....	11

## SECTION VIII

SYSTEM STAGE PARTS .....	11
SERVICE LAYOUTS .....	12
SPECIFICATIONS.....	16

## SECTION IX

FLOW DIAGRAMS FOR CBS & MCV.....	17
NOVATEK WARRANTY .....	19

## SECTION I

### GENERAL

This manual covers the operation and maintenance manual is furnished with each CBS-Contained Blasting System & MCV-Multi Component Recovery System. It outlines the general equipment use and the operation and maintenance requirement for efficient and safe operation. It is also important that the operator/user becomes familiar with the OSHA requirements for coatings removal, recovery and containment of hazardous wastes that may be generated.

### **READ ALL INSTRUCTIONS AND DATA IN THIS OPERATION AND MAINTENANCE MANUAL PRIOR TO OPERATION OF THIS EQUIPMENT.**

These instructions are for your protection and convenience. Please read them carefully since failure to follow the precautions could result in injury. Whenever using electric powered equipment, basic safety precautions should be followed.

If after reading this manual anything seems unclear, contact a **NOVATEK** authorized distributor or **NOVATEK** directly by dialing 1-866-563-7800.

## SECTION II

### KITS A & B

Designed to collect and contain abrasives and normal coating material in an efficient and safe manner. Blasting media will also be collected during this procedure.

### KITS C & D

Designed to collect coatings by blasting, as well as, contain normal and hazardous coating material in an efficient and safe manner. Blasting media will also be collected during this procedure.

### KITS A, B, C & D – MCV

Designed to supply a vacuum flow for power tools that remove coatings such as; by needle scaling, Scabblor and roto-penning. The same hazardous material removal recovery and containment capability is maintained in kits C & D

## SECTION III

### SAFETY

The Contained Blasting System (CBS) and Multi-Port Collection Vacuum (MCV) are highly efficient systems designed for collecting, filtering, and containment of normal or hazardous waste products generated from coating removal operations. In order to properly operate the system effectively and safely, the following should be strictly adhered to:

1. Do not leave either the CBS Workhead or blast pot connected to a compressed air supply line. Turn off air and disconnect unit from the air line when it is not in use or before servicing.
2. Follow the procedures outlined in this manual for safe and efficient use of the system. Use only **Novatek's** recommended parts and attachments.
3. Do not operate with damaged parts. If the vacuum or blasting system is not working as specified due to parts failure or misuse, repair damaged parts or return to a **Novatek** authorized distribution service center for inspection and repair as necessary. Always replace parts with genuine **Novatek** parts to insure operational safety and to protect your limited liability warranty.
4. Do not pull or carry the equipment by the air or vacuum lines, use the lines as handles, close doors on lines, or pull the lines around sharp corners or edges. Keep the lines away from heated surfaces or other harsh environments.
5. Do not operate with any opening blocked. Keep vacuum flow path clear of debris for safe efficient operation. Do not operate system with vacuum lines not connected to equipment to ensure that harmful debris will not be ingested.
6. Keep hair, loose clothing, fingers and all body parts away from the vacuum openings and moving parts of the tool during operation.
7. Do not ingest anything that is burning or smoking, such as hot ashes, matches or cigarettes.
8. Do not use the machine without the intermediate (cartridge) filter and or H.E.P.A. filter in place, when operating with hazardous materials.
9. Turn off all controls before disconnecting air supply.

10. Do not use without approved safety restraints when operating on stairs, ladders, etc.
11. Do not use in areas where flammable or combustible liquids, such as gasoline, may be ingested into the vacuum lines.
12. Do not use where oxygen or anesthetics are being used.
13. Hazardous waste generated during the operation of the contained blasting systems C and D and multi port collections systems must be managed in accordance with OSHA regulations to insure safe handling, equipment cleaning and containment in all respects.

## **SECTION IV**

### **EQUIPMENT IDENTIFICATION AND FIELD SET-UP**

Equipment configuration for the systems discussed in this manual are identified as to type and requirement layouts as follows:

Kit "A" – CBS – Contained Blasting System (Single Pump – No H.E.P.A.)  
 Kit "B" – CBS – Contained Blasting System (Dual Pump – No H.E.P.A.)  
 Kit "C" – CBS – Contained Blasting System (Single Pump – w/ H.E.P.A.)  
 Kit "D" – CBS – Contained Blasting Systems (Dual Pump – w/ H.E.P.A.)

Each system is discussed as to general assembly and setup requirements down to the stage level of detail. Follow the illustrations for the general equipment layout and equipment changes for each configuration. A brief discussion of each system follows:

#### **KIT "A & B" CBS**

General set up procedures and equipment are outlined in the next section. All blasting debris (grit and surface coating material) is collected in the recovery stage and remaining dust in the filter stage. Blasting media is also collected in the recovery stage. Kit "A" is supplied with a single vacuum pump and Kit "B" is supplied with dual vacuum pumps.

H.E.P.A. filter stage must be added to these kits if hazardous material coatings are being removed, in order to meet OSHA requirements. The dual vacuum pump may be required to accommodate the use of the #6 nozzle or the increased vacuum requirement for 5 or 8 vacuum tools.

#### **KIT "C & D" CBS**

General set up procedures and equipment arrangement are outlined in the next section. All blasting debris (grit and surface coating material) is collected in the recovery stage and remaining dust in the filter stage. Blasting media is also collected in the recovery stage. Kit "C" is supplied with a single vacuum pump and Kit "D" is supplied with a dual vacuum pump.

H.E.P.A. filter stage comes with these kits for containment of hazardous material coatings, in order to meet OSHA requirements. The dual vacuum pump may be required to accommodate the use of a #6 nozzle or the increased vacuum requirement for 5 to 8 vacuum tools.

#### **MCV – MULTI-PORT COLLECTION VACUUM**

The 4 port or 8 port manifolds, utilized vacuum power tools (VSE) to remove coating from surfaces and collect the debris consistent with requirements of collecting hazardous or non-hazardous debris from the removal process by means of vacuum collection.

These manifolds are sufficient to operate 2-8 (VSE) power tools like; needle guns (19/PG or 28/PG), grinders (2", 5" or 7") and roto-peens (2"-4").

## **SECTION V**

### **SET-UP PROCEDURE & EQUIPMENT DESCRIPTION**

#### **CBS KITS**

The general set-up area required should be reasonably flat, convenient to a compressed air facility and close to the equipment or surfaces to be blasted. Equipment will normally be skid mounted or located where debris can easily be moved from the area and blast material can easily be loaded into the blast pots. Skid or truck bed mounting will accommodate

moving from job to job. Units should be located to utilize the standard inter-connecting hose lengths furnished and positioned to allow accessibility for operators.

Parts list for each stage in the layout should be used to identify parts and assemblies utilized in these kits. These parts lists are identified as (1) Workhead, (2) recovery stage, (3) Pre-Filter stage, (4) H.E.P.A. filter stage, (5) Vacuum stage, (6) Hose & other ancillary equipment and compressed air system.

### **WORKHEAD & ASSOCIATED EQUIPMENT (OPTIONAL)**

The Workhead is partially assembled with the exception of the blast whip hose with coupling and the vacuum recovery hose with coupling. The Workhead assembly is shown in Assembly 1-1 and Parts List 1-1. Individual parts are listed in the parts list and referenced in each service layout.

- To complete the Workhead assembly, the blast hose is cut to a smooth perpendicular end with the suitable knife.
- This end is screwed into the non-threaded end of the nozzle holder until the hose end reaches the start of the machined internal thread.
- The locking ring is loosely assembled over the nozzle holder, the nozzle and locking ring assembly are screwed into the nozzle holder until glove tight, and insuring that the hose end and nozzle end seal are mated properly and sealed.
- The combined locking ring and nozzle assembly is inserted into the Workhead and locked into place by means of the locating pin and three internal locking screws.
- The nozzle and hose assembly should swivel freely in the Workhead.
- Connect the 3" vacuum hose to the Workhead by means of a hose clamp.

### **RECOVERY STAGE (1-2)**

The recovery stage is a pre-assembled drum lid with the inlet vacuum hose connected to a 3" Cam lock fitting with an internal elbow directed tangentially to the drum internal surface. The cyclonic action of the flow through the elbow drops larger particles of dirt and debris from the stream onto the drum base resulting in cleaner air being removed from the recovery stage through the 2<sup>nd</sup> Cam lock exhaust fitting and ducted to the filter stage 1-4. Both fittings are assembled with gasket and lock nuts. Flow direction is marked on the hose fittings and drum lid (color coded on hose end to match stage connector fittings). The drum top and drum top gasket are installed on the 55 gallon barrel.

### **FILTER (CARTRIDGE) STAGE (1-4)**

The filter unit is partly assembled on a 55 gallon drum lid with the inlet connected to a 3" Cam lock fitting. The outlet fitting supports the bracket, filter locating. Both fittings are assembled with gaskets and lock nuts. The filter cartridge is assembled on the bracket with furnished locking nut. The filter unit (1-4) will not pass particles of size greater than 3.0 micros. The drum top and drum top gasket are installed on the 55 gallon barrel.

### **H.E.P.A. FILTER STAGE (1-5)**

If the CBS operation is removing hazardous coating materials, a H.E.P.A. filter unit must be utilized. The H.E.P.A. filter unit will remove all material from the stream down to 0.3 micron size. The unit, if required, is delivered with the H.E.P.A. filter, implosion valve and vacuum gage installed. The implosion valve is set at 60" H<sub>2</sub>O vacuum to protect the enclosure. The vacuum gage is used to determine the filter condition, to be discussed further in the maintenance section. Vacuum hoses are color coded and flow direction indicators are marked to insure proper equipment installation orientation and vacuum flow.

### **VACUUM STAGE (1-6)**

The vacuum stage unit, as shipped, is almost completely assembled. The unit should be located to allow easy connection to the compressor and vacuum lines exiting the pre-filter or the H.E.P.A. filter stage according to the system requirements. The muffler is assembled to the vacuum stage unit with hardware supplied. Par list 1-6 defines specific equipment included. Specifications for the vacuum unit are defined in section 1-6. If dual flow vacuum units are required for use with the #6 blasting nozzles, the necessary parts are defined in the stage 1-6 parts list.

An optional dual vacuum pump may be required if a #6 nozzle is used in the Workhead. An additional dual vacuum manifold (314.D158) and a 6' vacuum hose with couplings (314.B104) will also be required.



## VAC & COMPRESSED AIR HOSE

The following interconnecting vacuum and air hoses or equipment are required to complete, or as extras (\*) to modify, the equipment installation.

- Vacuum Hose (50') from the Workhead is furnished, with the Workhead stage.
- Blast Hose (10' whip) is furnished with the Workhead stage.
- Additional Blast Hose ¾" or 1" diameter vacuum hose (3" diameter) in 50' length are available as an option to support Workhead operation from the blast pot.
- Air hose and compressor equipment (by others) may be required to support operation of the CBS Kits Flow vacuum operation.

## SECTION VI

### START-UP REQUIREMENTS

#### CBS KITS

After all equipment has been satisfactorily installed and checked out, the system is ready to be configured for start up. The following steps should be followed for the correct start up sequence.

1. Insure that all interconnection hoses, both vacuum and air, are laid out with no kinks, minimum bends and connectors complete and secure.
2. Insure that the Workhead and the shut off safety switch are assembled properly and connected securely at hose connectors.
3. Insure the operator is equipped with the recommended protective clothing and equipment in accordance with NIOSH
  - Air-fed hood
  - Remote controls
  - Canvas jacket, pants and leather gloves
  - Also recommended is that the air-lid hood be equipped with an air purifier, free air pump and or CO (Carbon Monoxide monitor).

### OPERATING PROCEDURE

#### Start-up

- Turn on compressed air.
- Open valve on vacuum pump air supply valve.

#### Blast Operation

- Pick up Workhead and remote control switch.
- Place Workhead brush in full contact with the work surface and close remote switch.
- A short delay will be observed until the abrasive reaches the Workhead.
- Adjustment of the pot regulators will adjust abrasive flow to the Workhead.
- Adjust regulators until the abrasive flow produces the desired amount of surface cleaning.
- The remote control must be depressed as long as blasting is required.
- The Workhead brush must be in constant contact with the work surface to achieve optimum vacuum recovery and control of abrasive and dust generation.

#### Routine Intermittent Shutdown

Release the remote control switch and the blasting will stop. The vacuum runs constantly while the vacuum pump unit is operating. The switch controls the blasting only. Keep the brush in full contact with the work surface to insure no escape of the blast abrasive during start-up and shutdown cycles.

#### Shutdown – Reloading Abrasives

- Release the remote control switch.
- Close the valve on vacuum pump air supply valve.
- Fill blast pot manually to desired capacity.

- To start blast operation again, open the air supply to the vacuum pump valve and open the blast pot air supply valve.
- Intermittent shutdowns provide a time for brush inspection for deterioration and replacement as well as inspection of vacuum for pressure leaks in the system.

#### **Shutdown – End of Work Period**

- Close the air supply valve on compression and shutdown in accordance with compressors manufacturers' instruction.
- Bleed off air in compression supply line by opening air supply valve until pressure is released, then close again.
- System is now de-pressurized.

#### **MAINTENANCE**

Periodic maintenance performed as scheduled will insure that the CBS equipment will operate at high efficiency with minimum unscheduled down time. The recommended program is as follows:

##### **Daily Maintenance**

- Check the operation protective equipment to ensure that all required equipment is being used and is in good working condition.
- All blast hose couplings must be properly safety wired or pinned.
- All rubber washers and seals on nozzles, blasting hose and air line couplings must be properly installed and in good condition.
- The Workhead nozzle must be tightly secured to the nozzle coupling. A rubber sealing washer must be used to prevent premature wear on the nozzle and coupling.
- Perform a daily inspection of all equipment to ensure that no damage was incurred over the shutdown period.

##### **Weekly Maintenance**

- Check the nozzle for wear. Maximum wear is defined when the nozzle diameter increases in size from ¼" to 3/8" for a #4 nozzle. Worn nozzles will reduce operating blasting pressure and will reduce production rate.
- Check blast and vacuum hoses for signs of wear or soft spots.
- Check all valves and controls for satisfactory operating condition.
- Check recovery, pre-filter and H.E.P.A. filters for satisfactory operation and recovery accumulated debris or dust if over ½" barrel deep.

##### **Monthly Maintenance (or approximately 200-500 hours of operation)**

- Check and if needed replace the filters.
- Check all seals for signs of wear and replace as needed.
- Hoses should be checked for signs of wear inside and outside.
- Replace drums with clean empty ones. Dispose of used drums according to local regulations.

## **SECTION VII**

#### **GENERAL H.E.P.A. FILTER CARE**

1. The **Novatek** CBS and MCV systems have been specifically designed to remove and contain hazardous material such as lead-based paint and asbestos while removing protective coatings. Special filters reduce the incidence of airborne contaminated dust that would be created by other methods of cleaning.
2. During the removal of protective coatings, asbestos dust, and other hazardous materials, do not sweep, scoop or shovel or in any manner handle other than by vacuuming as covered in this manual.
3. Do not attempt, at any time, to bypass, remove, substitute, or by any other means, change the filters in this system. Use only approved **Novatek** vacuum filters. Before attempting to use and before cleaning, be certain that you fully understand the instructions given for the setting up or cleaning/changing of filters in the vacuum unit.
4. The pre-filter stage on top of the 55 gallon drum removes the majority of dust and dirt before moving through the H.E.P.A. stage or vacuum pump.
5. The H.E.P.A. filter must be used when processing hazardous waste. This filter will pass only particles smaller than .3 microns which meets OSHA requirements. The small amount of dust that may be deposited in the upstream side of the filter should be removed and disposal in an OSHA approved and sealed bag.

6. In all cases filter should be replaced in stages 4 and 4a to minimize contamination and prolong the efficient operation of the H.E.P.A. filter.
7. H.E.P.A. filter replacement is accomplished by removing the H.E.P.A. filter box top and lifting the H.E.P.A. out of the unit. The heap filter must be disposed of in an OSHA approved and sealed bag. The new filters installed and filter box assembled making sure the assembly is properly sealed.

## **TROUBLESHOOTING**

### **Poor Production**

Low air pressure is the most common cause of poor production or performance. The poor operation is generally caused by one of the following:

- Compressor is too small for the nozzle being used.
- Air line I.D. is too small. Air line size should be a minimum of 1 ¼" diameter.
- Air restriction in the line caused by improper fittings. Blasting pressure should be 100 psi minimum measure at the nozzle.

### **Pulsating or Surging of Nozzle Flow**

**NOTE:** It is normal to have an initial surge of grit due to accumulated grit in the hose and nozzle. Normal flow will occur in a few seconds.

- Choke valve is partially closed.
  - The choke valve should be open during blasting operations.
- Operating with damp abrasives.
  - Grit must be absolutely dry to flow evenly through the blast hose and nozzle. On humid days or with a filter open to weather, correct operation may require operating with the moisture separator drain cock slightly open. If this does not correct the problem an air dryer system may be required in line between the compressed air source and the blast machine.

### **Flow of Air Through the Nozzle, But Little or No Flow of Abrasives**

- Blast pot is empty – refill with abrasives.
- Contaminated abrasives.
  - Inspect to see if contaminants are introduced at the blaster.
- Clogged grit valve.
  - Adjust the grit valve to full open position while the machine is blasting. Close the choke valve for a few seconds – then open it fully. Repeating this sequence three or four times should clear any temporary blockages.

## **SECTION VIII**

### **SYSTEM STAGE PARTS LISTS**

#### **CBS Kit "A" (Figure #1, Page 18)**

<b><u>PART #</u></b>	<b><u>KIT DESCRIPTION</u></b>
CBS0100	Recovery Stage
CBS0200	Filter Cartridge Stage
CBSD153	Vacuum Pump Stage

#### **CBS Kit "B" (Figure #2, Page 19)**

<b><u>PART #</u></b>	<b><u>KIT DESCRIPTION</u></b>
CBS0100	Recovery Stage
CBS0200	Filter Cartridge Stage
CBSD153	Vacuum Pump Stage (2 pieces)
CBSD149	Dual Pump Manifold
CBSD158	Dual Vacuum Manifold Complete

**CBS Kit "C" (Figure #3, Page 19)**

<u>PART #</u>	<u>KIT DESCRIPTION</u>
CBS0100	Recovery Stage
CBS0200	Filter Cartridge Stage
CBSD153	Vacuum Pump Stage
CBSD153	H.E.P.A. Stage

**CBS Kit "D" (Figure #4, Page 19)**

<u>PART #</u>	<u>KIT DESCRIPTION</u>
CBS0100	Recovery Stage
CBS0200	Filter Cartridge Stage
CBSD153	Vacuum Pump Stage (2 pieces)
CBS0014	H.E.P.A. Stage
CBSD149	Dual Pump Manifold
CBSD158	Dual Vacuum Manifold Complete

**SERVICE LAYOUTS**

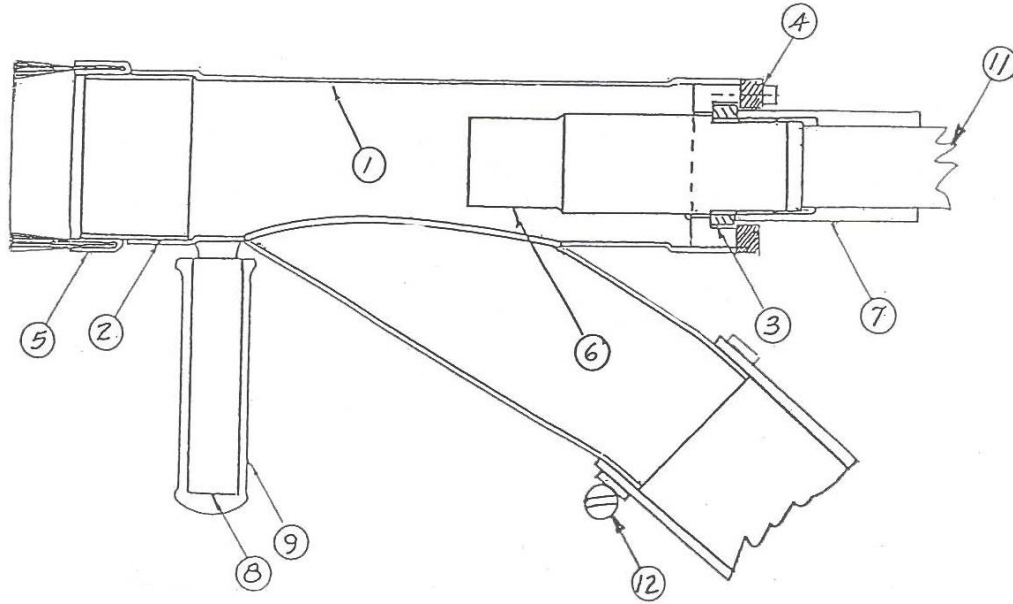

**(1-1)**  
Workhead Stage  
**CBS0008**

<b>REF. #</b>	<b>PART #</b>	<b>STAGE DESCRIPTION</b>
-	CBS0020	Workhead Kit
-	CBS0015	Workhead Complete (Included in Workhead Kit)
1	CBSA001	Workhead Steel Body
2a	CBSA032	2" Steel Insert Sleeve (3pc)
2b	CBSA033	3" Steel Insert Sleeve (2pc)
2c	CBSA034	4" Steel Insert Sleeve (2pc)
3	CBSA020	Threaded Locating Ring
4	CBSA015	Locking Ring w/ hardware
5a	CBSA030	3" Flat Brush (3pc)
5b	CBSA029	3" Outside Corner Brush (2pc)
5c	CBSA028	3" Inside Corner Brush (2pc)
6a	CBSA004	#4 Nozzle
6b	CBSA006	#6 Nozzle
7	CBSD005	3/4" Nozzle Holder
8	CBSA016	Steel Handle
9	CBSA018	Grip
10	CBSD305	50' Vac Hose 3" diameter
*	CBSB300	Female Hose Coupling (Not Shown)
11	CBSD075	3/4" Blast Hose – 10' length
*	CBSD015	Chicago Fitting for Blast Hose (Not Shown)
12	CBSD310	3" Hose Clamp

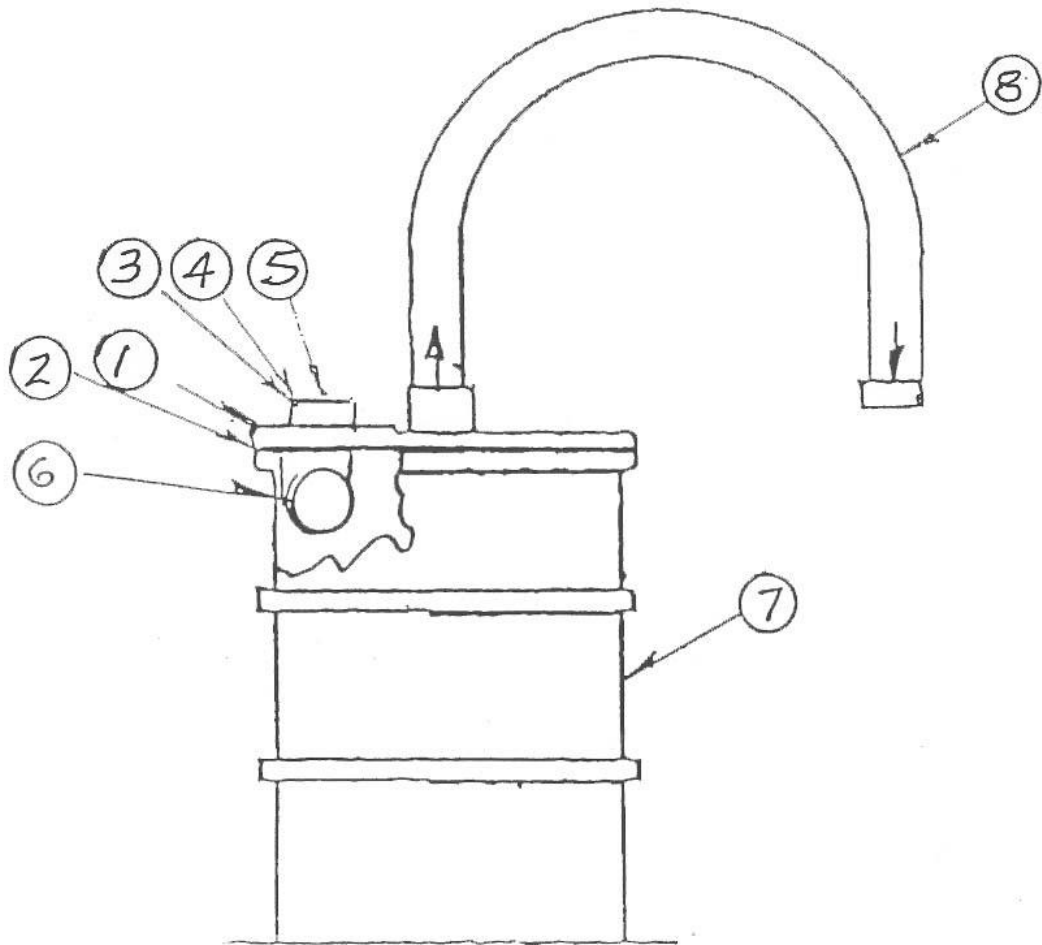

**(1-2)**  
 Recovery Stage (Lid Assembly)  
**CBS0100**

	<b>PART #</b>	<b>STAGE DESCRIPTION</b>
1	CBSB100	Drum Top
2	CBSB105	Drum Top Gasket
3	CBSB305	3" Hose Couplings (2)
4	CBSB312	3" Coupling Gaskets (2)
5	CBSB315	3" Lock Nuts
6	CBSB102	3" Elbow
7	CBSB055	Barrel 55 Gallon (Customer Supplied)
8	CBSB104	3" Vac Hose w/ Couplings – 6' length

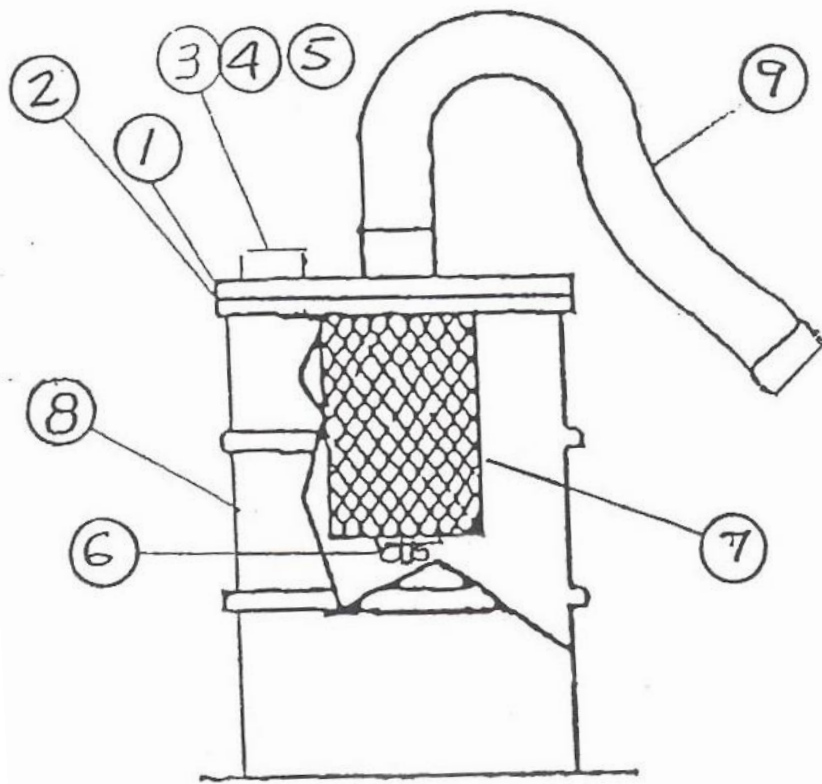

**(1-3)**  
 Filter Stage  
 CBS0200

<u>REF. #</u>	<u>PART #</u>	<u>STAGE DESCRIPTION</u>
1	CBSB100	Drum Top
2	CBSB105	Drum Top Gasket
3	CBSB305	3" Hose Couplings, Cam Lock (2)
4	CBSB312	3" Coupling Gaskets (2)
5	CBSB315	3" Lock Nuts
6	CBSB120	Bracket Assembly Filter Locating
7	CBSB600	Filter Cartridge
8	CBSB055	Barrel 55 Gallon (Customer Supplied)
9	CBSB104	3" Vac Hose w/ Couplings – 6' length

\* For dual pump vacuum pump installation without H.E.P.A. filter additional equipment required

10	CBSD158	Dual Vac Manifold (not shown)
11	CBSB305	3" Male Hose Coupling
12	CBSB104	Vac Hose – 3" diameter – 6' length

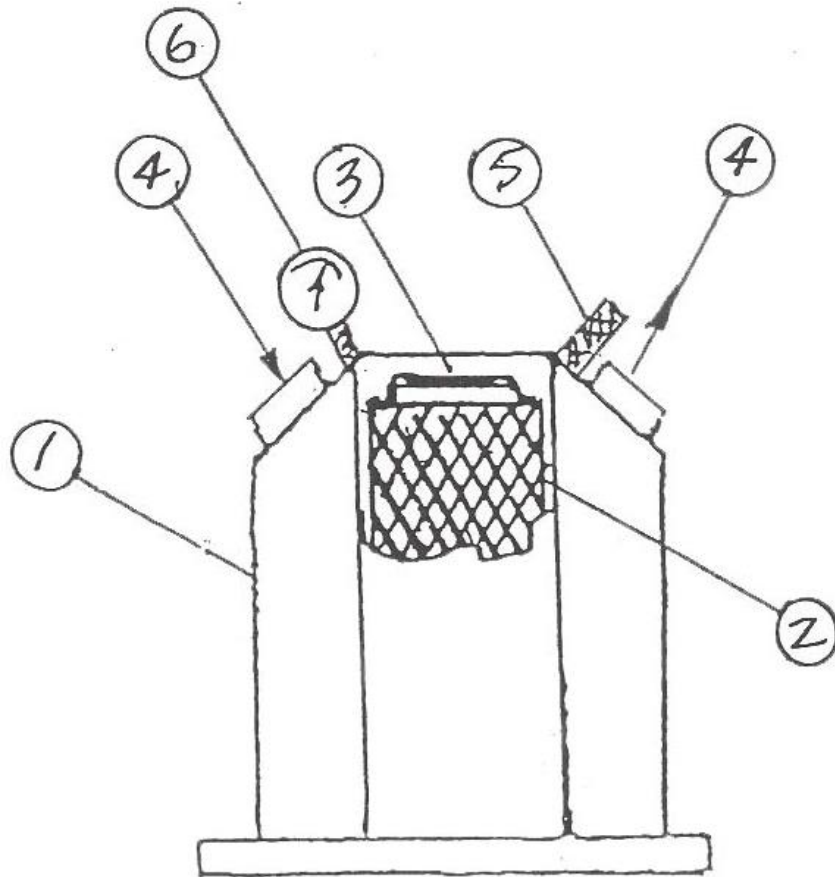

**(1-4)**  
**H.E.P.A. Filter Stage**  
**CBS0014**

<u>REF. #</u>	<u>PART #</u>	<u>STAGE DESCRIPTION</u>
1	CBSC002	Filter Housing (H.E.P.A.) Complete/HWD
2	CBSC010	H.E.P.A. Filter
3		Filter Brackets
4	CBSB305	3" Hose Couplings (2)
5	CBSC020	Valve, Implosion (2" NPT)
6	CBSC026	Gauge Plug (3/4" NPT)
7	CBSB104	3" Vac Hose w/ Couplings – 6' length

\* For dual vacuum pump installation additional equipment required \*

8	CBSD158	Dual Vac Manifold
9	CBSB305	3" Male Hose Coupling
10	CBSB104	Vac Hose – 3" diameter – 6' length



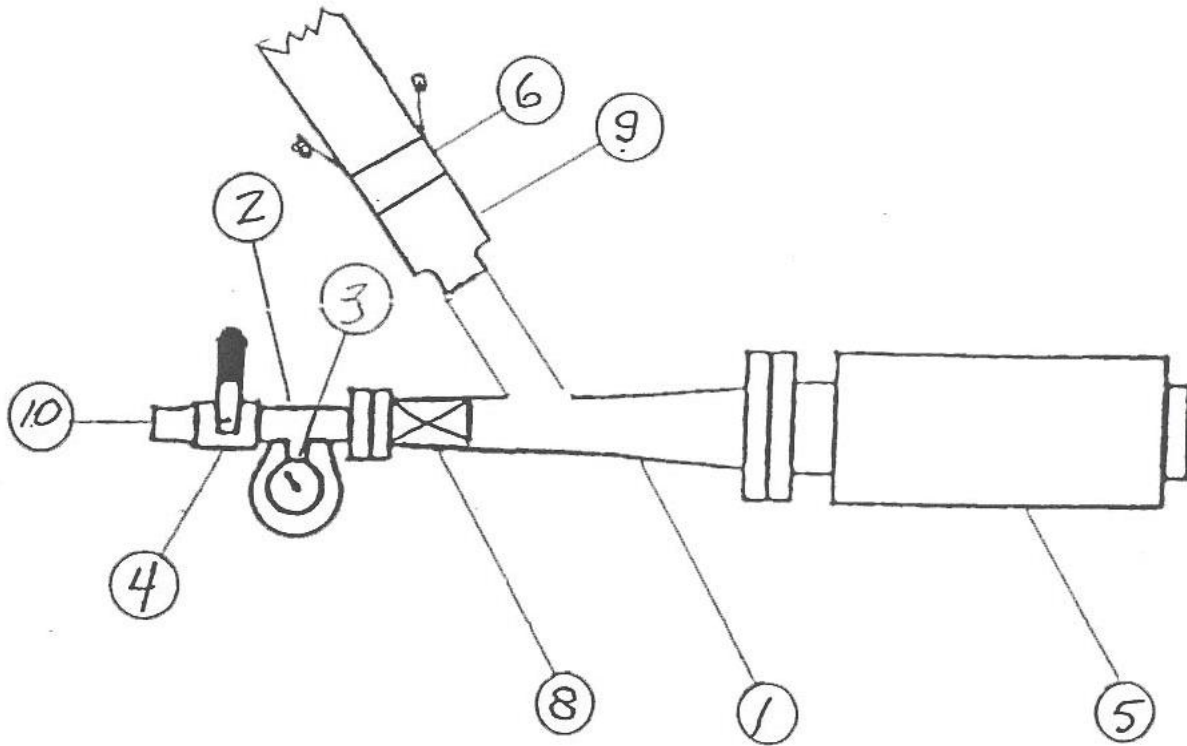

**(1-5)**  
**Vacuum Pump**  
**CBSD153**

<u>REF. #</u>	<u>PART #</u>	<u>STAGE DESCRIPTION</u>
1	CBSD150	Venture Assembly
2	CBSD105	Gage Mount
3	CBSD100	Gage
4	CBSD160	Valve, Ball (1 1/4")
5	CBSD151	Muffler/Flange w/ Hardware
6	CBSB305	Vac Hose Assembly Fitting – Cam Lock (3")
8	CBSD112	Venturi Nozzle – 3/8" Standard
8	CBSD110	Venturi Nozzle – 1/4" Optional
9	CBSD155	3" – 2" Reducer – Optional
10	CBSD154	Pipe Nipple (2") – Optional

\* For dual vacuum pump installation additional equipment required \*

CBSD149      Dual Pump Manifold

**SPECIFICATIONS**

Air Requirements	CFM / Static Lift Output Flow	Blast Operation		Bulk Tool Operation	
		# 4 Blast 1/4" Nozzle	# 6 Blast 3/8" Nozzle	1-4 Tools	5-8 Tools
1- Vacuum Pump 200 CFM @ 100 PSI	360cfm @13"Hg	X		X	
2 – Vacuum Pumps 400 CFM @ 100 PSI	720cfm @13"Hg		X		X

**SECTION IX**

**FLOW DIAGRAMS FOR CBS AND MCV**

**CBS Kit "D" Shown**

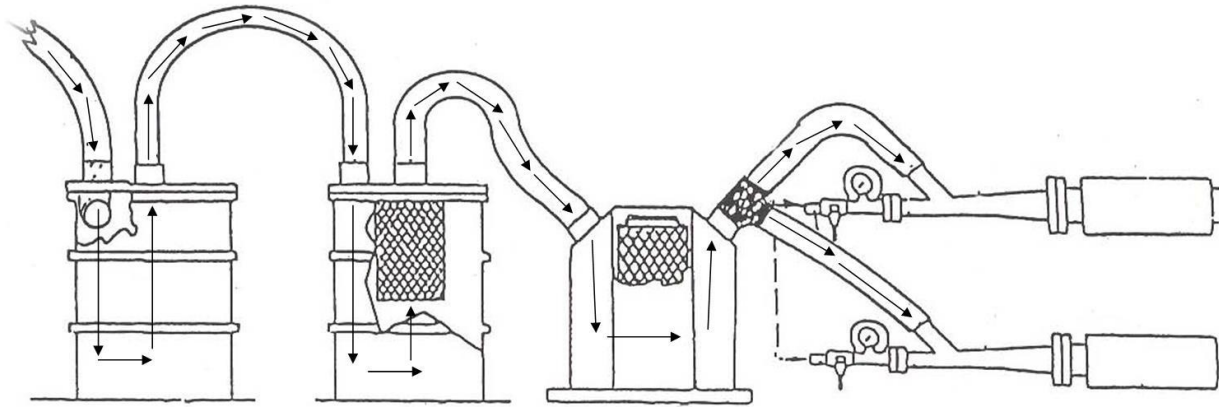

**Figure #2  
CBS Kit "A" - Single Pump**

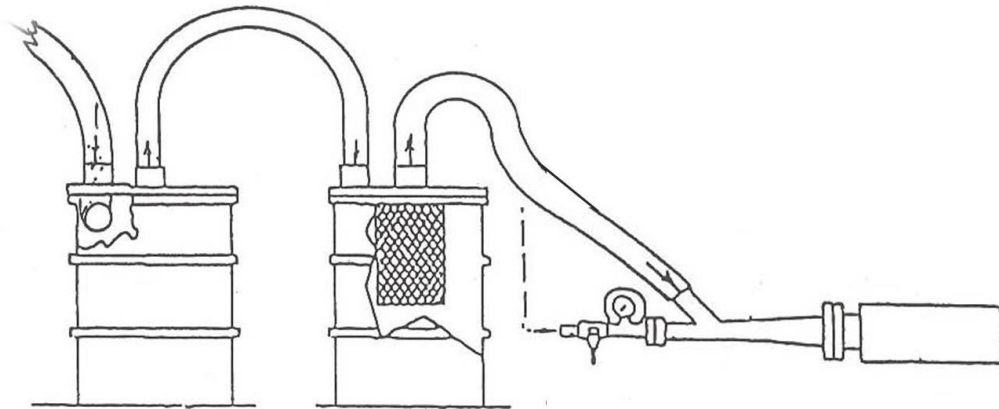

**Figure #3**  
**CBS Kit "B" – Dual Pump**

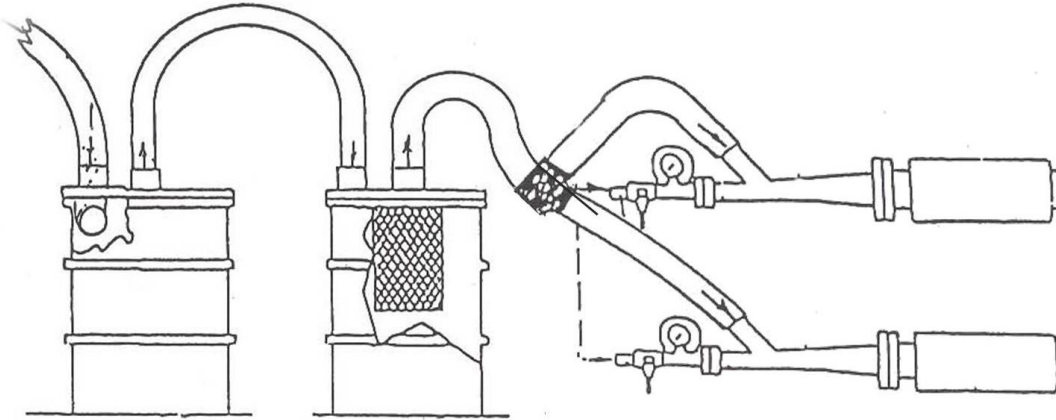

**Figure #4**  
**CBS Kit "C" – Single Pump w/ H.E.P.A.**

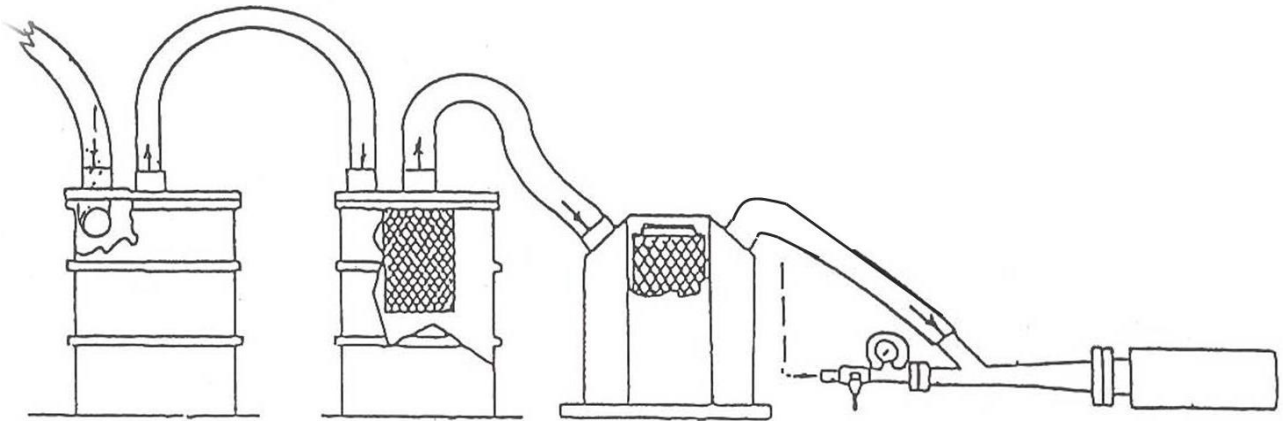

**Figure #5**  
**CBS Kit "D" – Dual Pump w/ H.E.P.A.**

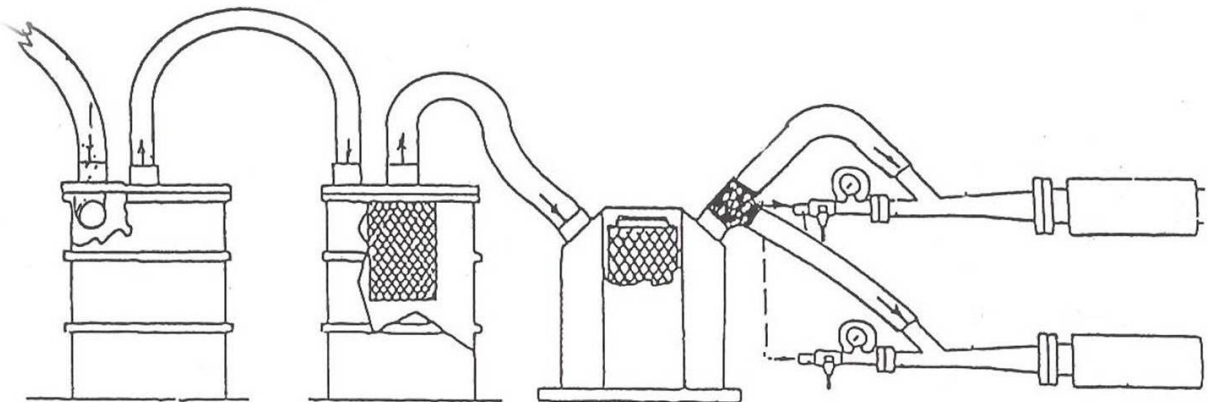

## NOVATEK CORPORATION LIMITED WARRANTY

The **TOOLS** manufactured/distributed by **Novatek Corporation** are warranted to be free from defects in material and workmanship for a period of **ONE YEAR** with the exception of Electric Drive Units, Electric Motors and Air Blowers - **6 months warranty applies on the electric components** from the date of purchase. This warranty does not apply to accessories or parts subject to normal wear.

This warranty applies only to **TOOLS** purchased new from **NOVATEK CORPORATION** or an authorized distributor. This warranty does not apply to any **TOOL** which has been abused, misused, modified or repaired by someone other than **NOVATEK CORPORATION** or its authorized repair center.

If a **TOOL** proves defective in material or workmanship within one year of purchase from **NOVATEK CORPORATION**, it should be returned to **NOVATEK CORPORATION**, transportation pre-paid. The return must be authorized by a **RETURN MERCHANDISE AUTHORIZATION NUMBER (R.M.A. #)** obtained from **NOVATEK CORPORATION** prior to returning the **UNIT**. All packages must show clearly on the outside the return merchandise authorization number. All packages received without any R.M.A. # on the outside will be refused by **NOVATEK CORPORATION** receiving department.

Warranty claims will only be considered upon adequate proof of date of purchase. **NOVATEK CORPORATION** will, at its option, **REPAIR or REPLACE DEFECTIVE PARTS**. Repairs or replacements are warranted as above for the remainder of the original warranty period. The sole liability of **NOVATEK CORPORATION** and the user's exclusive remedy under this warranty is limited to the repair or replacement of the defective product.

THERE ARE NO OTHER WARRANTIES EXPRESSED OR IMPLIED AND **NOVATEK CORPORATION** SHALL NOT BE LIABLE FOR INCIDENTAL, CONSEQUENTIAL OR SPECIAL DAMAGES OR ANY OTHER EXPENSES OR REPAIR OR REPLACEMENT AS DESCRIBED ABOVE.

All warranty claims should be forwarded to:

**NOVATEK CORPORATION**  
**254 Welsh Pool Road**  
**Exton, PA 19341**

**ATTENTION: CLAIM AND SERVICE DEPARTMENT**  
**R.M.A. # \_\_\_\_\_**

**CALL Toll Free at 1-866-563-7800 for your RMA number prior to shipping.**

Also include a brief description of the problem as well as a phone number, contact name and return address in case **NOVATEK CORPORATION** service personnel has to get in contact with you.