



## Shrouded Right Angle Grinder 5" & 7" Operations & Maintenance

SRAT5A - Air 5"  
SRAT7A - Air 7"  
SRAT5E - Electric 5"  
SRAT7E - Electric 7"



© Copyright 2014 by NOVATEK Corporation

All rights reserved printed in the United States of America. No part of this manual may be used or reproduced in any form or by any means, stored in data base or retrieval system, without prior written permission from NOVATEK Corporation.

Making copies of this manual for any purpose other than your own personal use is a violation of the United States copyright laws.

March 1, 2016 issue 1.0

**Specifications subject to changes without notice!**

If you have any questions, please contact us:

NOVATEK CORPORATION

254 Welsh Pool Rd

Exton, PA 19341

USA

[www.novatekco.com](http://www.novatekco.com)

Toll Free 866 563-7800

Telephone: +1 610 363-7800

Fax +1 610 935-1945

Email: [Sales@Novatekco.com](mailto:Sales@Novatekco.com)

# OPERATION AND MAINTENANCE MANUAL FOR

## SHROUDED RIGHT ANGLE GRINDERS 5" AND 7"

### NOTICE

#### FOR PROFESSIONAL USE ONLY



### WARNING



**IMPORTANT SAFETY INFORMATION ENCLOSED.  
READ AND UNDERSTAND THIS MANUAL BEFORE OPERATING THIS PRODUCT.**

**IT IS YOUR RESPONSIBILITY TO MAKE THIS SAFETY INFORMATION  
AVAILABLE TO OTHERS THAT WILL OPERATE THIS PRODUCT.**

**FAILURE TO OBSERVE THE FOLLOWING WARNING COULD RESULT IN INJURY.**



#### PLACING TOOL IN SERVICE

- Always install, operate, inspect and maintain this product in accordance with all applicable standards and regulations (local, state, country, federal, etc.).
- Compressed air models always use clean, dry air at 90 psi (6.2bar/620kPa) maximum air pressure at the inlet. Higher pressure may result in hazardous situations including excessive speed, rupture, or incorrect output torque or force.
- Electric models must always utilize proper gauge, and rated electrical cords with correct connections.
- Be sure all hoses and fittings are the correctly sized and secured.
- Ensure an accessible emergency shut off has been installed in the air or electrical supply line. Make others aware of its location.
- Do not use damaged, frayed, or deteriorated air hoses and fittings.
- Always use proper gauge electrical cords with correct connections. (When applicable.)
- Electric models must not use damaged, frayed, or deteriorated electrical cords and connections.
- Keep clear of whipping air hoses. Shut off the compressed air before approaching a whipping hose.
- Always turn off and disconnect the tool from its power supply before installing, removing or adjusting any accessory, or before performing any maintenance on the tool.
- Do not lubricate tools with flammable or volatile liquids such as kerosene, diesel or jet fuel. Use only recommended lubricants.
- Keep work area clean, uncluttered, ventilated and illuminated.
- Keep all electrical connections clear of water or other liquids. (When applicable.)
- Do not operate the machine while flammable or volatile liquids such as gasoline, diesel or jet fuel are present. Failure to do so can result in explosion. (When applicable.)
- Do not remove any labels. Replace any damaged label.

#### USING THE TOOL

- Always wear protection when operating or performing maintenance on this tool.
- Always wear hearing protection when operating this tool.
- Always use Personal Protective Equipment appropriate to the tool used and material worked. This may include dust mask or other breathing apparatus, safety glasses, ear plugs, gloves, apron, safety shoes, hard hat and other equipment,
- Prevent exposure and breathing of harmful dust and particles created by power tool use:
  - Some dust created by power sanding, sawing, and grinding, drilling, and other construction activities contains chemicals known to cause cancer, birth defects or other reproductive harm. Some examples of these chemicals are:
    - Lead from lead based paints,
    - Crystalline silica from bricks and cement and other masonry products, and
    - Arsenic and chromium from chemically treated lumber
- Your risk from these exposures varies, depending on how often you do this type of work. To reduce your exposure to these chemicals: work in a well ventilated area, and work with approved safety equipment, such as those dust masks that are specially designed to filter out microscopic particles.
- Keep others a safe distance from your work area, or ensure they use appropriate Personal Protective Equipment.
- This tool is not designed for working in explosive environments, including those caused by fumes and dust, or near flammable materials.

- Electrically powered tools are not insulated against electric shock.
- Be aware of buried, hidden or other hazards in your work environment. Do not contact or damage cords, conduits, pipes, or hoses that may contain electrical wires, explosive gases or harmful liquids.
- Keep hands, loose clothing, long hair and jewelry away from working end of tool.
- Power tools can vibrate in use. Vibration, repetitive motions or uncomfortable positions may be harmful to your hands and arms. Stop using any tool if discomfort, tingling feeling or pain occurs. Seek medical advices before resuming use.
- Keep body stance balanced and firm. Do not overreach when operating this tool. Anticipate and be alert for sudden changes in motion, reaction torques, or forces during startup and operation.
- Tool and/or accessories may briefly continue their motion after throttle is released,
- To avoid accidental starting – ensure tool in “off” position before applying air pressure or connecting to electricity. Avoid throttle when carrying, and release throttle with loss of air or electricity.
- Ensure work pieces are secure. Use clamps or vises to hold work piece whenever possible.
- Do not carry or drag the tool by the hose or power cord.
- Do not use power tools when tired, or under the influence of medication, drugs, or alcohol.
- Never us a damaged or malfunctioning tool or accessory,
- Do not modify the tool, safety devices, or accessories.
- Do not use this tool for purposed other than those recommended.
- Use accessories recommended by Novatek Corp.
- Never operate a tool with an accessory unless it is properly installed and the tool is held firmly against the work,
- Always use a retainer, when furnished, in addition to proper barriers to protect persons in surrounding or lower areas from possible ejected accessories.
- When wearing gloves and operating models with inside trigger, always be sure that the gloves will not prevent the trigger from being released.
- Wear safety shoes, hard hat, safety goggles, gloves, dust mask and any other appropriate protective clothing while operating the tool.
- Do no indulge in horseplay. Distraction can cause accidents.
- Keep hands and fingers away from the throttle lever until it is time to operate the tool.
- Never rest the tool on your foot.
- Never point the tool at anyone.
- Compressed air is dangerous. Never point an air hose at yourself or others.
- Never blow clothes free of dust with compressed air.
- Be sure all hose connections are tight. A loose hose not only leaks but can come completely off the tool and while whipping under pressure, can injure the operator and other in the area. Attach safety cables to all hosed to prevent injury in case a hose is accidentally broken.
- Never disconnect a pressurized air hose. Always turn off the air supply and bleed the tool before disconnecting a hose.
- When applicable, the operator must keep limbs and body clear of the chisel. If a chisel breaks, the tool with the broken chisel projecting from the tool will suddenly surge forward.
- Do not ride the tool with one leg over the handle. Injury can result if the chisel breaks while riding the tool.
- Know what is underneath the material being worked. Be alert for hidden water, gas, sewer, telephone or electric lines.
- Use only proper cleaning solvents to clean parts. Use only cleaning solvents which meet current safety and health standards. Use cleaning solvents in a well ventilated area.
- Do not flush the tool or clean any parts with diesel fuel. Diesel fuel residue will ignite in the tool when the tool is operated, causing damage to internal parts. When using models with outside triggers or throttle levers, take care when setting the tool down to prevent accidental operation.
- Do not operate the tool with broken or damaged parts.
- Never start the tool when it is lying on the ground.
- This tool is not designed for working in explosive atmospheres.



## SECTION I

### GENERAL

This operation and maintenance manual is furnished with each R/A Shrouded Grinder Tool purchased. It outlines the general operation and maintenance items critical to insure satisfactory, safe and long life of the R/A Shrouded Grinder and accessories.

### **READ ALL INSTRUCTIONS AND DATA IN THIS OPERATION AND MAINTENANCE MANUAL PRIOR TO OPERATION OF THIS EQUIPMENT.**

These instructions are for your protection and convenience. Please read them carefully since failure to follow the precautions could result in injury. Whenever using electric powered equipment, basic safety precautions should be followed.

If after reading this manual anything seems unclear, contact a **NOVATEK** authorized distributor or **NOVATEK** directly by dialing 1-866-563-7800.

## SECTION II

### BEFORE USE

Inspect the tool's external parts, fittings and assemblies for loose or damaged parts prior to use.

**CAUTION: DO NOT inspect the tool without first disconnecting it from the power supply!**

### IN USE

- A. Always use the correct abrasive discs.
  - B. Experimentation with various disc materials and abrasive materials may be beneficial in terms of productions.
  - C. The electric motor switch should be in the "off" position when not in use.
  - D. After proper power has been supplied the switch should be turned to the "on" position.
  - E. The drive motor is capable of various rotational speeds. To determine optimal rotational speeds, refer to the instructions provided with the abrasives.
  - F. No attempt should be made to increase or decrease the grinders rotational speed setting recommended for each individual abrasive. Always follow manufacturer's recommendations. Failure to do so could result in premature wear or failure of the abrasive disc.
- If the tool produces unusual sounds or vibrates excessively, shut down immediately for repair or return for factory inspection.
  - Exposure to excessive vibrations or repetitive work practices may be harmful. The use of gloves will help dampen vibrations during prolonged use.
  - Due to fire hazards, do not use gasoline or volatile thinners to flush or clean the tool in any way.
  - Maintenance and repair records should be kept on all grinders.
  - Frequency and nature of repair may reveal unsafe operational conditions.

## SECTION III

### CLEANING

#### **Shroud Assemblies**

- At intervals of no more than 50 hours of operation, or weekly, clean the tool externally and internally by removing the shroud end plate. Inspect the hub assembly and cutting flap units and cutter heads for wear and damage.
- Use a high flash point solvent to flush debris.
- Replace or repair any defective parts found.
- Replace the end plate and run the tool to check for satisfactory operation.

#### **Air Drive Motors**

- Air drive motors require very little normal maintenance if proper air filtration and inline lubricator is installed.
- Daily external cleaning and inspection is recommended.
- Reconditioning of air drive motors after warranty operation.

#### **Electric Drive Motors**

- If inspection indicates a buildup of dust inside the cover, this build up may be removed by blowing compressed air through the air slots.
- If excessive brush sparking is observed through the air inlet slots, switch the machine off immediately to avoid serious damage which can occur with prolonged operation.

## **LUBRICATION**

Input a few drops of oil daily through the air inlet fitting with any industry approved air tool lubricant. Suitable oil is NFO's Air Lube (10W/NR) or equivalent light machine oil (10W). A suitable air line filter and an in line lubricator are also strongly recommended.

The drive R/A Air Motor Drive Case should be checked for oil level at the filler screw oil port. A few drops of gear lube must be added daily for satisfactory trouble free operation. A sample of the gear lube recommended is included and can be obtained as Castrol AW-68, Dryden EP-68#2, or equivalent.

## **SECTION IV**

### **ASSEMBLY AND DISMANTLING**

The tool consists of three assemblies, the right angle drive air motor, and the shroud assembly. Normal maintenance operation will require periodic inspection, lubrication and cleaning of the components. The right angle drive air motor requires only periodic inspection. Lubrication as recommended for air motor. If a problem occurs during the warranty period, the drive assembly should be returned for warranty inspection for repair or replacement.

### **DRIVE AIR MOTOR INSPECTION AND REPAIR**

In the event that the Right Angle Drive Air Motor is beyond warranty (1 year) and the user wishes to recondition the Air Drive Motor, the following steps should be taken to inspect and recondition the unit, if not returned to **Novatek** for service.

**WARNING** Following reconditions of Right Angle Drive Air Motor it is critical to insure the no load speed of the motor is approximately 5500 RPM +/- 100 RPM. Over or under torque of the air motor assembly will result in deviations of rotational speeds. The no load speed must be checked following assembly each time the abrasive is secured to the locking position.

- Release the locking screw on back flange and unscrew using pink key and end wrench.
- Place tool in vice, clamping across flats on throttle housing, unscrew lock ring. (Note: Left hand thread on angle head casting, right hand thread on motor housing.)
- Pull motor assembly out and unscrew throttle assembly from motor housing, ease out rear spacer, coupling and front spacer.
- To disassemble the motor, grip rotor spines in soft jaws of vice and unscrew nut for RA5 (left hand thread).
- Displace cylinder to one side and insert stripped block between bearing housings.
- Using stripper plate, pass rear bearing housing into hole "A" so that the edge of the cylinder lodges on one side and the stripper block on the other.
- Push rotor through from splined end. Pass rotor through hole "B" and press out from rear bearing housing.
- Remove space and vanes. To remove bearing from housings, place over hole "B" and push out with punch.
- To disassemble the angle head assembly, grip casting in soft jaws, unscrew bearing housing and withdraw whole spindle assembly unit.
- Remove circlip. Remove bearing by sliding into slot "E" in stripper plate, support stripper plate either side of bearing and press out.
- Slide off circlip. Press off gear wheel and ease out woodruff key.
- Press out spindle by placing blocks either side of bearing housing with thread in downward position.
- Turn bearing housing over and press out bearing with punch.
- The throttle unit can be disassembled by removing plug, O-ring and valve spring.
- Withdraw valve stem and O-ring and with suitable punch, tap out lever pin and remove throttle lever.

**NOTE: Stripping Tool Kit (part no. RPTA529) should be ordered and available prior to disassembly of the Air Drive Motor. These special stripping or disassembly tools along with the following instructions are supplied for customers who wish to carry out their own repairs. These repairs should only be undertaken if trained personnel and approved speed testing equipment are available.**

## **AIR POWERED UNITS**

- Use a minimum 3/8" diameter air hose in conjunction with a minimum of 30 SCFM of compressed air rated at 90 psi. Assure your fitting is compatible to the tool's 3/8" MQC air inlet plug. A supply of clean, dry air is required and suitable filter lubrication is recommended for trouble free use.

**WARNING** Air inlet plugs less than 3/8" will not supply sufficient air flow to the grinders for satisfactory operation.

- Tighten all hose connector fittings and blow out hose to insure that all debris is purged from the supply line.
- Put a few drops of light machine oil into the air inlet of the tool on a daily basis prior to start up and at shut down. (See recommended air tool lubricants.)
- Remove screw (#24) and add a few drops of gear lube into the gear head.

**WARNING** Failure to lubricate the gear head may result in unsatisfactory performance, premature failure and may void the warranty.

- The air motor drive unit requires the correct air input fitting to be installed (part no. 818.0255) to insure the 3/8" plug size is used.

## **ELECTRIC POWERED UNITS**

Insure that 110 volt / 10 amp electrical power is available. Power cords should be limited to 50 feet in length and be a minimum of 14 gauges / three wires.

- Daily inspection of the electrically powered grinder is required to insure safe and reliable operation. The daily inspection consists of the following:
  - Wipe down the outside surface of the R/A gear drive until and electric motor enclosure to remove accumulated dirt, dust and other residue from the grinder preceding cleaning operation.
  - Check for loose or damaged parts. Tighten or replace as necessary.
  - Clear out any dust or debris from the inside of the motor case by means of compressed air jet through the cover case cooling slots.
  - Test run the motor to insure no arcing is indicated between the brush and commutator. If arcing takes place and additional air jet cleaning does not correct the problem, contact Novatek or an authorized Novatek distributor.
  - Check the R/A gear drive by rotation the output shaft to determine any roughness in the bearing or gear meshing during rotation. If roughness is indicated, inspect the tool per the corrective action section of this manual.

### **Periodic Inspections and Maintenance Requirements**

Electric motor arcing between the commutator and brushes indicated poor contact due to dirt accumulation, worn brushes or worn commutator.

- A. Clear out any dust or debris from the inside of the motor case by means of compressed air jet through the cover case cooling slots.
- B. If poor operation continues, contact Novatek or an authorized Novatek distributor.

**If roughness of the R/A gear is detected, please contact Novatek or an authorized Novatek distributor.**

## **CLEANING, INSPECTION AND PARTS REPLACEMENT**

All parts should be collected in order of disassembly, cleaned in a suitable solvent and inspected for damage or excessive wear. All renewal parts required should be ordered to support reassembly and return to service. It should be noted that certain parts should be stocked, based on experience, to support a rapid repair cycle.

- A. Press bearings into housings and insert spacer into rear housing with taper facing away from housing.
- B. Insert threaded end or rotor into rear housing and press fully home using hole "C".
- C. Fit vanes into rotor. Place cylinder over rotor, locating pin in small hole in rear housing.
- D. Locate front bearing housing over splines and use bush to push bearing and housing fully home.
- E. Grip splines in soft jaws and screw on nut, left hand thread.
- F. Slide assembly into motor housing so that approximately 7mm of front bearing housing can be seen protruding, replace spacer.
- G. In the event that vanes are not free to move in rotor slots, they should be replaced with a new set.

- H. Reassemble throttle by fitting O-ring to valve stem. Fit valve stem, spring, O-ring and throttle plug.
- I. Fit lever together with spring if fitted and pin. Screw the throttle assembly into rear of motor housing.
- J. To assembly angle head, place bearing over hole "D" in stripper plate and press on spindle right home to shoulder.
- K. With bearing housing over hole "B", thread upward, place spindle (thread downward) and bearing over housing and with tube press bearing on outer race fully home.
- L. Fit woodruff key, gear wheel, circlip and oiler. Place bearing over hole "C" and, with threat at top, press spindle into bearing up to the shoulder.
- M. Fit circlip. Locate spindle assembly into angle head. Screw bearing housing in and tighten.
- N. Press two bearings onto pinion using hole "C" in stripped plate slid pinion assembly into angle head housing and mesh gears.  
Locate front space onto pinion bearings and fit coupling onto pinion splines.
- O. There should now be two sub-assemblies for the right angle drive air motor"
  - 1 – The angle head assembly.
  - 2 – The motor and throttle assembly with lock-ring separate.
- P. Replace back flange and tighten lock screw.

**ELECTRIC DIRVE MOTOR SUB-ASSEMBLY INSPECTION**

In the even the electric drive unit has accumulated 800 hours +/- any increment there after (1,000, 1,500 etc.), the drive unit should be inspected as required to maintain warranty coverage.

Tool Model: Right Angle Grinder Air Motor (only)  
Part Number: SRAT5A & SRAT7A

<b><u>Ref #</u></b>	<b><u>Part #</u></b>	<b><u>Description</u></b>
1A	SRATARA5	Right Angle Motor Complete
1	RPTA735	Motor Housing
2	RPTA930	Angle Head
3	RPTA685	Lock Ring
4	RPTA686	Rotor
5	RPTA451	Cylinder
6	RPTA421	Vanes (5 off)
7	RPTA415	Rear Bearing Housing
8	RPTA346	Front Bearing Housing
9	RPTA101	Rotor Spacer
10	RPTA604	Bearing
11	RPTA689	Bearing
12	RPTA722	Bearing
13	RPTA723	Bearing
14	RPTA605	Bearing
15	RPTA725	Spindle
16	RPTA100	Circlip
17	RPTA142	Circlip
18	RPTA724	Bearing Housing
19	RPTA727	Gear Wheel & Pinion Set (#19 &#20)
20	RPTA727	Pinion & Gear Wheel Set (#19 &#20)
23	RPTA104	Back Nut
24	RPTA249	Oiling Screw
25	RPTA254	Oiler – Gear Lube
26	RPTA626	Rear Space
27	RPTA172	Wood Ruff Key
28	RPTA728	Front Spacer
29	RPTA729	Coupling
30	RPTA730	Back Flange
34	RPTA732	Silencer Cover & Screws
35	RPTA342	Lever
36	RPTA756	Side Handle
38	RPTA718	Throttle Housing
39	RPTA719	Throttle Lever Assembly
40	RPTA141	Lever Pin
41	RPTA330	O-ring
42	RPTA143	Throttle Valve Stem
45	RPTA146	Throttle Plug
46	RPTA177	Lever Return Spring
52	RPTA108	Locking Screw (2)



**RIGHT ANGLE AIR MOTOR SUB-ASSEMBLY**  
 Part No. SRATARA5

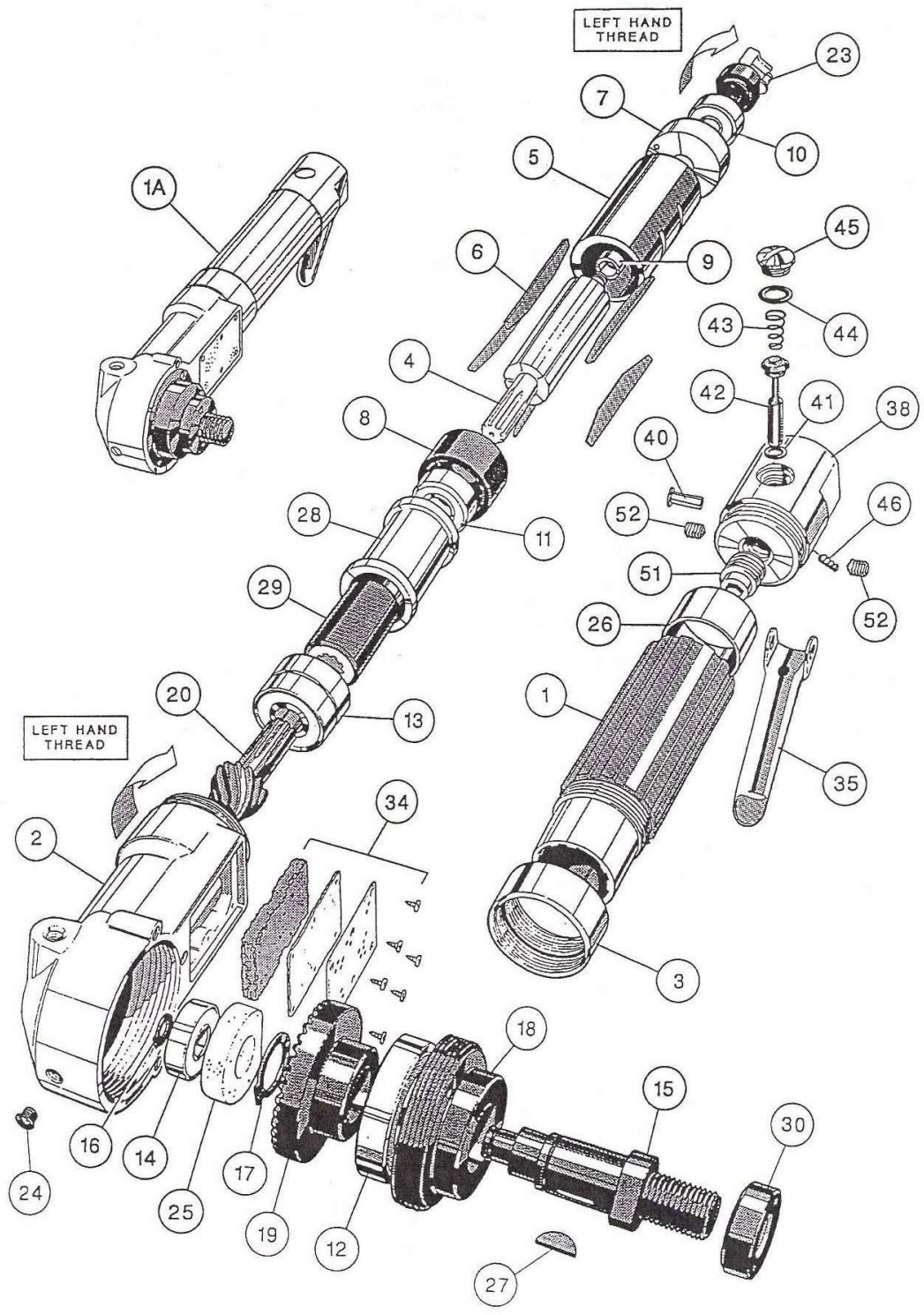

**SERVICE LAYOUT # 2**

The following two tool service layouts, with referenced part numbers, are used throughout this manual to help identify parts and location for disassembly, assembly and general service procedures. The first layout covers the R/A Air Motor Assembly and the second layout covers the remainder Shroud & Hub Assemblies.

Tool Model: Floating Head Shroud Assembly  
 Part Number: SRAT5A, SRAT5E, SRAT7A, SRAT7E

<b><u>Ref#</u></b>	<b><u>Part#</u></b>	<b><u>Description</u></b>
70	RPTAU68	MOUNTING COLLAR – SHROUD TO AIR MOTOR AIR
	RPTEU68	MOUNTING COLLAR – SHROUD TO ELECTRIC MOTOR
71	SRATG005	SHROUD ASSEMBLY-5" COMPLETE (includes 70, 72, 73, 74)
	SRATG007	SHROUD ASSEMBLY-7" COMPLETE (includes 70, 72, 73, 74)
Not Shown	SRATGA01	SCREW/LOCK WASHER (SET)-SHROUD TO MOTOR AIR
	SRATGE01	SCREW/LOCK WASHER (SET)-SHROUD TO MOTOR ELEC
72	SRATG205	SHROUD CAST HOUSING – 5"
	SRATG207	SHROUD CAST HOUSING – 7"
73	SRAT7315	SKIRT 5"- FLOATING HEAD SHROUD ONLY
	SRAT7317	SKIRT 7"- FLOATING HEAD SHROUD ONLY
74	SRATG206	FLEXIBLE SHROUD ASSEMBLY 5"
	SRATG208	FLEXIBLE SHROUD ASSEMBLY 7"

**CONSUMABLE REPLACEMENT PARTS AVAILABLE**

66	SRATM105	BACKING PAD (5") FOR COATING REMOVAL DISC
	SRATM107	BACKING PAD (7") FOR COATING REMOVAL DISC
	SRATP105	BACKING PAD (5") FOR SILICON CARBIDE DISC
	SRATP107	BACKING PAD (7") FOR SILICON CARBIDE DISC
67	SRATM005	DISC-CLEANING & COATING REMOVAL (5")
	SRATM007	DISC-CLEANING & COATING REMOVAL (7")
	SRATP005	DISC-SILICON CARBIDE (5")

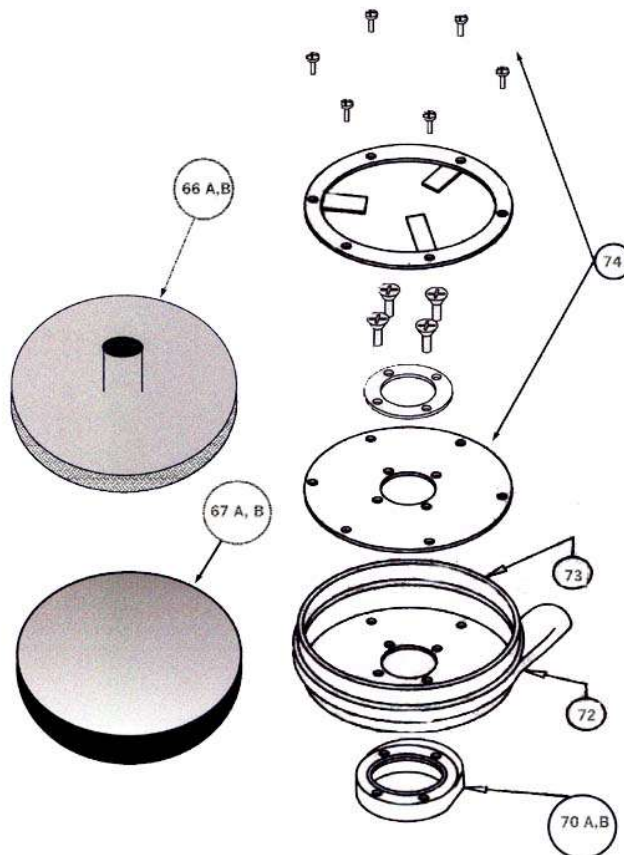

## NOVATEK CORPORATION LIMITED WARRANTY

The **TOOLS** manufactured/distributed by **Novatek Corporation** are warranted to be free from defects in material and workmanship for a period of **ONE YEAR** with the exception of Electric Drive Units, Electric Motors and Air Blowers - **6 months warranty applies on the electric components** from the date of purchase. This warranty does not apply to accessories or parts subject to normal wear.

This warranty applies only to **TOOLS** purchased new from **NOVATEK CORPORATION** or an authorized distributor. This warranty does not apply to any **TOOL** which has been abused, misused, modified or repaired by someone other than **NOVATEK CORPORATION** or its authorized repair center.

If a **TOOL** proves defective in material or workmanship within one year of purchase from **NOVATEK CORPORATION**, it should be returned to **NOVATEK CORPORATION**, transportation pre-paid. The return must be authorized by a **RETURN MERCHANDISE AUTHORIZATION NUMBER (R.M.A. #)** obtained from **NOVATEK CORPORATION** prior to returning the **UNIT**. All packages must show clearly on the outside the return merchandise authorization number. All packages received without any R.M.A. # on the outside will be refused by **NOVATEK CORPORATION** receiving department.

Warranty claims will only be considered upon adequate proof of date of purchase. **NOVATEK CORPORATION** will, at its option, **REPAIR or REPLACE DEFECTIVE PARTS**. Repairs or replacements are warranted as above for the remainder of the original warranty period. The sole liability of **NOVATEK CORPORATION** and the user's exclusive remedy under this warranty is limited to the repair or replacement of the defective product.

THERE ARE NO OTHER WARRANTIES EXPRESSED OR IMPLIED AND **NOVATEK CORPORATION** SHALL NOT BE LIABLE FOR INCIDENTAL, CONSEQUENTIAL OR SPECIAL DAMAGES OR ANY OTHER EXPENSES OR REPAIR OR REPLACEMENT AS DESCRIBED ABOVE.

All warranty claims should be forwarded to:

**NOVATEK CORPORATION**  
**254 Welsh Pool Rd**  
**Exton, PA 19341**

**ATTENTION: CLAIM AND SERVICE DEPARTMENT**  
**R.M.A. # \_\_\_\_\_**

**CALL Toll Free at 1-866-563-7800 for your RMA number prior to shipping.**

Also include a brief description of the problem as well as a phone number, contact name and return address in case **NOVATEK CORPORATION** service personnel has to get in contact with you.